

Edytor Mariusz Młynarczyk
 Telefon 501 740 626
 faks
 e-Mail mlynarczyk_mariusz@wp.pl

OMS Classic T8 PAR 350G 4x18W / Karta danych oprawy

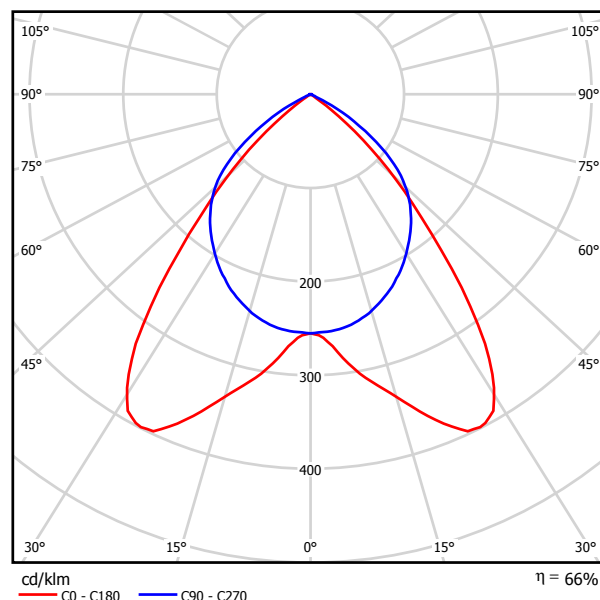

Wylot światła 1:



Klasyfikacja oświetleń CIE: 100
 Kod Flux CIE: 71 98 100 100 66

CLASSIC

Description

The Classic range of light fixtures are designed for ceiling installations as surface mounted. Using suitable accessories, most of the light fittings can also be used as pendant fittings.

Construction

Body: sheet steel, electrostatic powder coat finish - basic shade RAL 9003 (signal white, glossy), RAL 7001 (silver grey) on request. Bottom sheet can be delivered in two variants: solid (L1) and perforated (L2).

Louvers: LA, LAM, LB, PAR, PAR MAT, PAR-V, PAR MAT-V

Diffuser: made of PMMA in opal or prismatic (PS) finish. Optionally, both types can be made of polycarbonate.

Reflector: additional top reflector (REF version) on request for T5 parabolic louver versions, an asymmetric reflector is also available

The optical system is held by four clamping springs that allow easy lamp replacement.

Classic ASR: three lamp, impact-resistant version, developed especially for lighting of sport halls and areas, where higher protection against impacts coming from different directions is needed for luminaires. Optical part (parabolic louver) is protected with a plastic cover (clear PC), which is built in sheet frame and secured to the luminaire's body by four clamping springs. Suspended and surface mounted versions available.

Wiring

Light fixtures can be equipped with:

- conventional control gears, standard class EEI=B2, class EEI=B1 is available on request, light fixtures are standardly compensated
- electronic control gears, standard class EEI=A2
- dimmable electronic control gears, class EEI=A1 (electronic control gears can be controlled with analogue, digital or DALI signals)

Other components:

- lamps: linear fluorescent lamps T5 (16 mm), T8 (26 mm) - lamps must be ordered separately
- solid copper internal conductors, PVC insulated (heat resistant up to 90°C) with 0.5 mm² diameter
- a screwless three or five pole terminal allows connecting conductors up to 2.5 mm² cross-section
- an emergency version of light fixtures with autonomous operation of 1 or 3 hours is available on request

Accessories

- suspension accessories
- lamp holders allowing semi-recess mounting of light fixtures (ASN T5 version)

in case of semi-recessed or pendant installation, the fixtures can be equipped with connectors allowing fast electrical connection: 3-pole connectors Wieland gesis GST 18i3, Wago Winsta 770, AAG Stucchi

Wylot światła 1:

Oszacowanie oślepienia według UGR											
ρ Sufit	70	70	50	50	30	70	70	50	50	30	
ρ Ściany	50	30	50	30	30	50	30	50	30	30	
ρ Podłoga	20	20	20	20	20	20	20	20	20	20	
Koordinaty pomieszczenia x y	Kierunek spojrzenia w poprzek do osi lampy					Kierunek spojrzenia wzdłuż do osi lampy					
2H	2H	14.1	15.1	14.4	15.3	15.5	16.3	17.2	16.5	17.5	17.7
	3H	14.0	14.8	14.3	15.1	15.3	16.1	17.0	16.4	17.3	17.5
	4H	13.9	14.7	14.2	15.0	15.2	16.1	16.9	16.4	17.1	17.4
	6H	13.8	14.6	14.2	14.9	15.2	16.0	16.7	16.3	17.0	17.3
	8H	13.8	14.5	14.1	14.8	15.1	16.0	16.7	16.3	17.0	17.3
4H	12H	13.8	14.4	14.1	14.7	15.1	15.9	16.6	16.3	16.9	17.2
	2H	14.2	15.0	14.5	15.2	15.5	16.1	16.9	16.4	17.2	17.5
	3H	14.0	14.7	14.4	15.0	15.3	16.0	16.7	16.4	17.0	17.3
	4H	14.0	14.5	14.3	14.9	15.2	15.9	16.5	16.3	16.9	17.2
	6H	13.9	14.4	14.3	14.8	15.1	15.9	16.4	16.3	16.7	17.1
8H	12H	13.8	14.3	14.3	14.7	15.1	15.8	16.3	16.2	16.7	17.1
	12H	13.8	14.2	14.2	14.6	15.0	15.8	16.2	16.2	16.6	17.0
	4H	13.9	14.3	14.3	14.7	15.1	15.8	16.3	16.2	16.7	17.1
	6H	13.8	14.1	14.2	14.6	15.0	15.7	16.1	16.2	16.5	17.0
	8H	13.7	14.0	14.2	14.5	15.0	15.7	16.0	16.2	16.5	16.9
12H	12H	13.7	13.9	14.2	14.4	14.9	15.7	15.9	16.1	16.4	16.9
	4H	13.8	14.2	14.2	14.6	15.0	15.8	16.2	16.2	16.6	17.0
	6H	13.7	14.0	14.2	14.5	15.0	15.7	16.0	16.2	16.5	16.9
8H	13.7	13.9	14.2	14.4	14.9	15.7	15.9	16.1	16.4	16.9	
Wariacja pozycji obserwatora dla odstępów opraw S											
S = 1.0H	+2.3 / -8.2					+1.5 / -2.1					
S = 1.5H	+3.9 / -16.7					+2.4 / -7.3					
S = 2.0H	+5.7 / -23.2					+4.2 / -17.3					
Tabela standardowa	BK00					BK00					
Składnik sumy korekty	-5.8					-3.7					
Poprawione wskaźniki oślepienia odniesione do 5400lm Całkowity strumień świetlny											

1601A/1602A (on request: connectors ISODOM, 5-pole connectors Wieland gesis GST 18i5, Wago Winsta 770)

PAR (T8)

Double parabolic louvre with parabolic crossblades made of specular anodised aluminium is mechanically designed to give maximum efficiency and controlled light distribution. Thanks to the double-curved parabola is ideal to be used in rooms featuring computers, where good visual comfort is required. The light output is optimised by perfect quality aluminium that can has over 95% reflectance (MIRO). This types of louvers provides highest visual komfort at the screen due to exact glare evaluation.

Low glare of the louvre is in accordance with european standard EN 12464-1 for lighting of workplaces equipped with display screens - DSE (limits 200 resp. 1000 /m2 at 65o elevation).

Aluminium (PAR): Alanod: 350G (316G2, MIRO4 on request)

Aluminium (PAR-V): Alanod: 316G2 (MIRO4 on request)

Edytor Mariusz Młynarczyk
 Telefon 501 740 626
 faks
 e-Mail mlynarczyk_mariusz@wp.pl

KLASY 1/2 PARTER / Podsumowanie

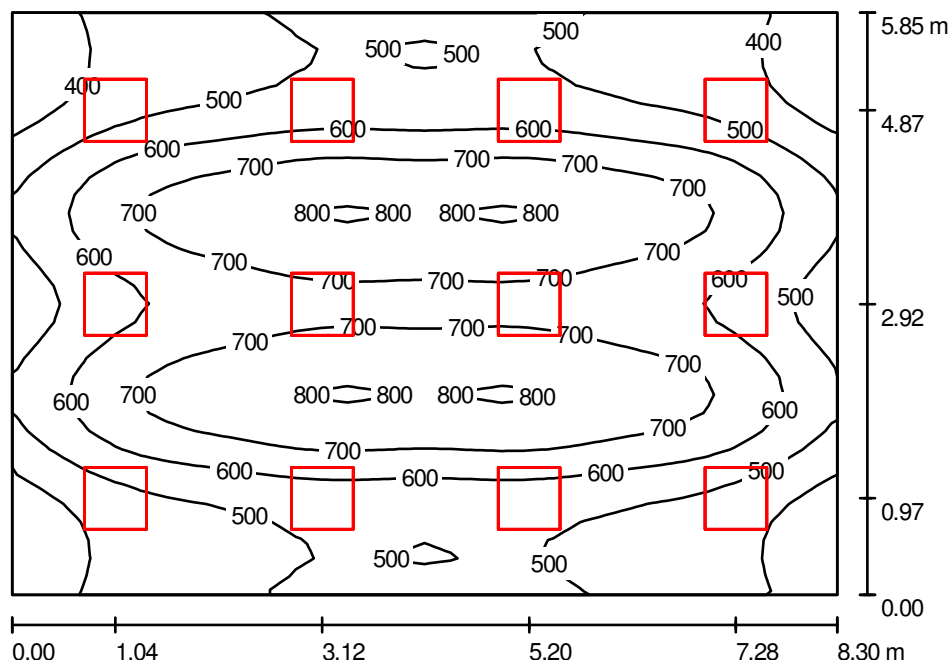

Wysokość pomieszczenia: 3.300 m, Wysokość montażu: 3.300 m,
 Współczynnik konserwacji: 0.77

Wartości Lux, Skala 1:76

Powierzchnia	ρ [%]	E_m [lx]	E_{min} [lx]	E_{max} [lx]	E_{min} / E_m
Płaszczyzna pracy	/	588	323	814	0.550
Podłoga	20	524	303	705	0.578
Sufit	70	109	86	122	0.790
Ściany (4)	50	232	81	387	/

Płaszczyzna pracy:

Wysokość: 0.850 m
 Siatka: 32 x 32 Punkty
 Margines: 0.000 m

UGR

Lewa ściana 14
 Dolna ściana 14
 (CIE, SHR = 0.25.)

Wzdłuż-

W poprzek

14 16
 14 16

do osi oświetlenia

Wykaz opraw

Nr.	Ilość	Etykieta (Czynnik korekcyjny)	Φ [lm]	P [W]
1	12	OMS Classic T8 PAR 350G 4x18W (1.000)	5400	72.0
			W sumie: 64800	864.0

Specyfikacja mocy przyłączeniowej: $17.79 \text{ W/m}^2 = 3.03 \text{ W/m}^2/100 \text{ lx}$ (Powierzchnia podstawowa: 48.56 m^2)

Edytor Mariusz Młynarczyk
 Telefon 501 740 626
 faks
 e-Mail mlynarczyk_mariusz@wp.pl

KLASY 1/2 PARTER / Oprawy (plan rozmieszczenia)

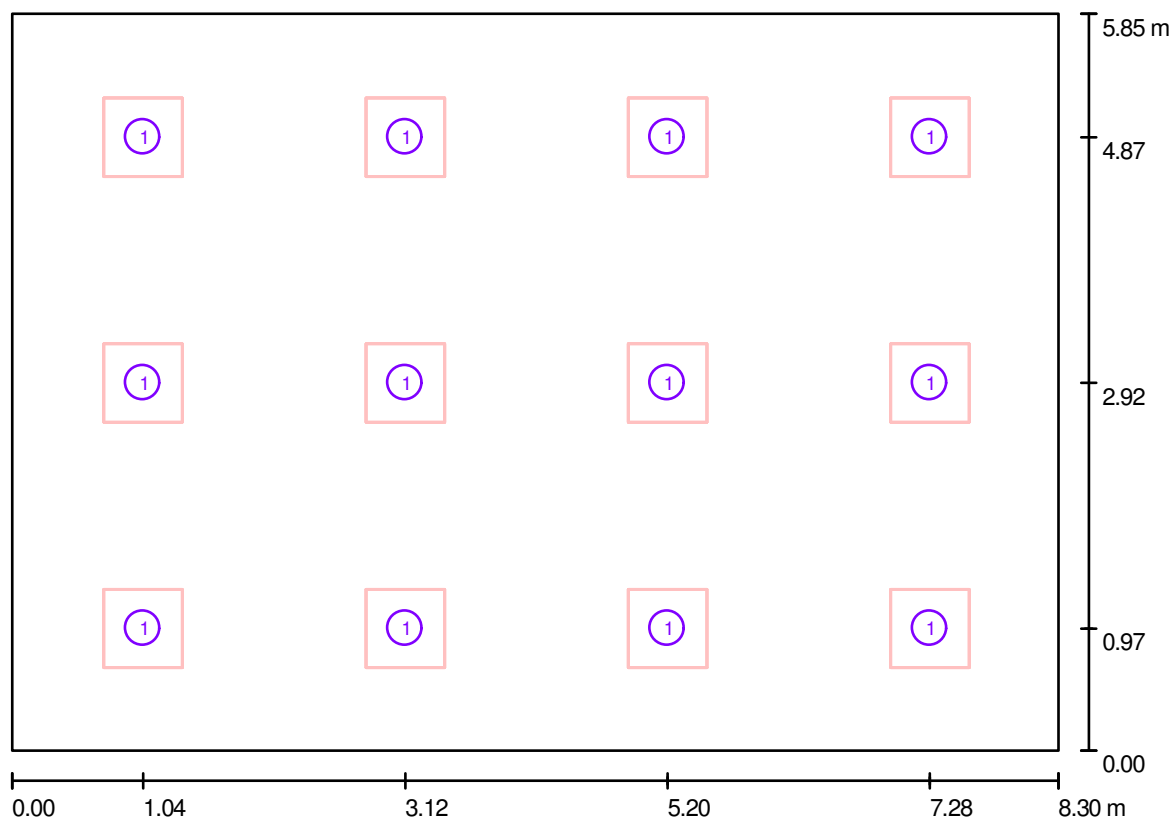

Skala 1 : 60

Wykaz opraw

Nr.	Ilość	Etykieta
1	12	OMS Classic T8 PAR 350G 4x18W

Edytor Mariusz Młynarczyk
 Telefon 501 740 626
 faks
 e-Mail mlynarczyk_mariusz@wp.pl

KLASY 1/2 PARTER / Oprawy (lista współrzędnych)

OMS Classic T8 PAR 350G 4x18W

5400 lm, 72.0 W, 1 x 4 x T8 18W (Czynnik korekcyjny 1.000).

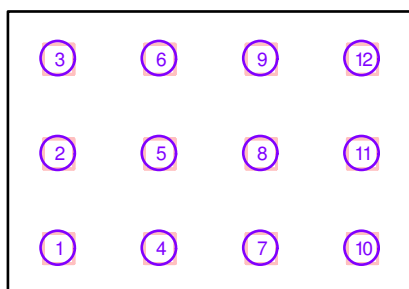

Nr.	Pozycja [m]			Rotacja [°]		
	X	Y	Z	X	Y	Z
1	1.040	0.970	3.300	0.0	0.0	90.0
2	1.040	2.920	3.300	0.0	0.0	90.0
3	1.040	4.870	3.300	0.0	0.0	90.0
4	3.120	0.970	3.300	0.0	0.0	90.0
5	3.120	2.920	3.300	0.0	0.0	90.0
6	3.120	4.870	3.300	0.0	0.0	90.0
7	5.200	0.970	3.300	0.0	0.0	90.0
8	5.200	2.920	3.300	0.0	0.0	90.0
9	5.200	4.870	3.300	0.0	0.0	90.0
10	7.280	0.970	3.300	0.0	0.0	90.0
11	7.280	2.920	3.300	0.0	0.0	90.0
12	7.280	4.870	3.300	0.0	0.0	90.0

Edytor Mariusz Młynarczyk
 Telefon 501 740 626
 faks
 e-Mail mlynarczyk_mariusz@wp.pl

KLASY 1/2 PARTER / Płaszczyzna pracy / Izolinie (E)

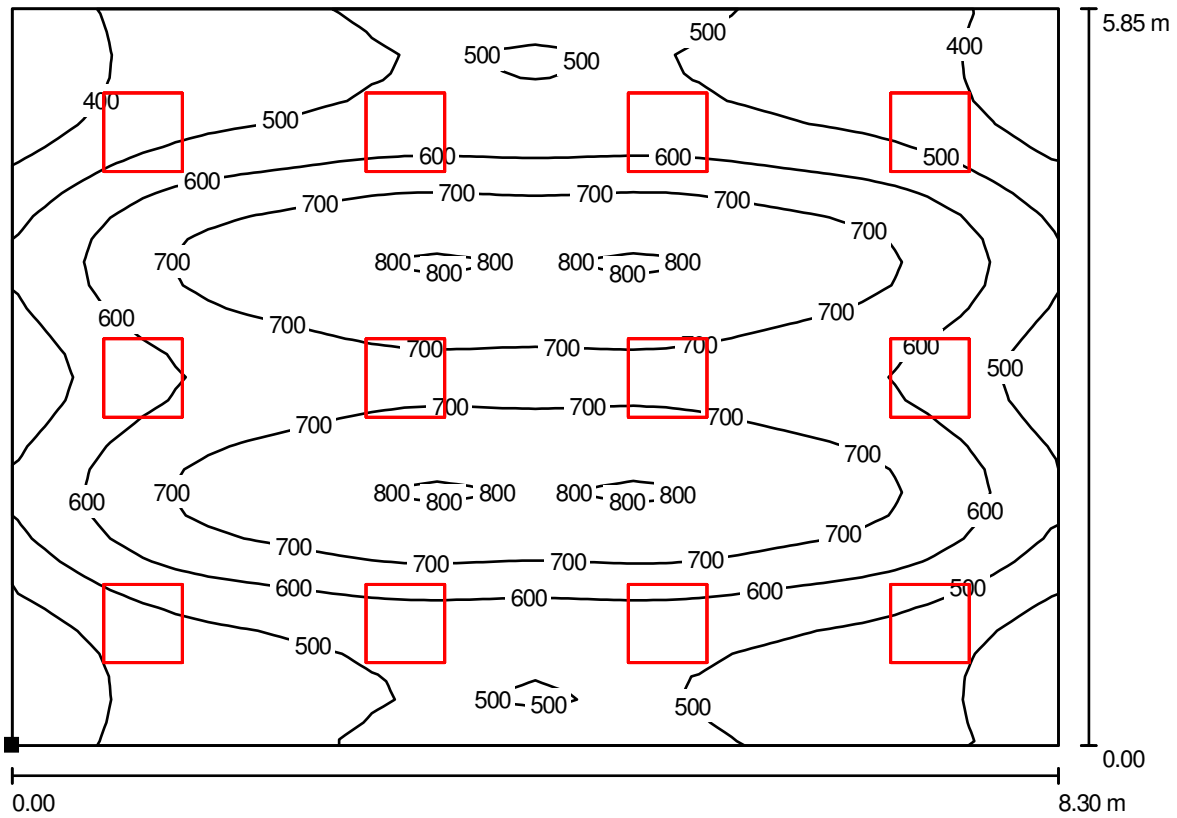

Wartości Lux, Skala 1 : 60

Położenie powierzchni w pomieszczeniu:
 Zaznaczony punkt:
 (0.000 m, 0.000 m, 0.850 m)



Siatka: 32 x 32 Punkty

E_m [lx]
588

E_{min} [lx]
323

E_{max} [lx]
814

E_{min} / E_m
0.550

E_{min} / E_{max}
0.397